



STORMSHIELD



GUIDE

STORMSHIELD NETWORK SECURITY

SN-XS-SERIES QUICK INSTALLATION GUIDE

Document last updated: Septembre 27 2024

Document version: 1.0

Reference: [sns-en-SN-XS-Series_quick_installation_guide](#)



Table des matières

- Getting started 3
- Installing the firewall 4
 - Installing firewalls on a shelf 4
 - Installing firewalls with a DIN rail 4
 - Installing firewalls against a wall 5
- Plugging in and starting the firewall 6
 - Plugging in the firewall 6
 - Connecting to the firewall 7
 - Troubleshooting 7
- Shutting down the firewall 8
- Documentation 9



Getting started

Welcome to the SN-XS-Series firewall quick installation guide.

Before you install your Stormshield Network firewall, carefully read and follow the safety instructions given in the document [Safety Rules and Installation Precautions](#).

The packaging contains:

- Your Stormshield Network firewall,
- A power adapter,
- A 2-pole threaded connector,
- An RJ45 crossover cable,
- An "A to C" USB cable,
- A DIN rail,
- Four non-slip rubber feet.



Installing the firewall

Take note of the registration password and serial number indicated on the underside of your firewall, which you will need during installation.

Installing firewalls on a shelf

Place the firewall horizontally on its non-slip rubber feet, or install it in a racking bay by using a rackable shelf.

Refer to the section [Installation in a 19" cabinet and rack](#) in the *Product presentation and installation guide* for more information.

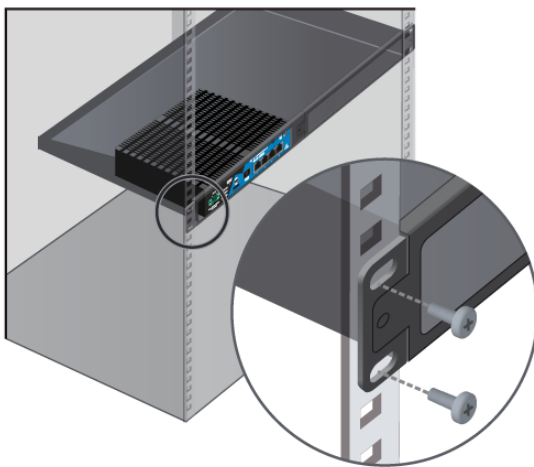

Installing firewalls with a DIN rail

Install the firewall by using the mounting system provided in the kit. DIN rails must be screwed onto the firewall in advance.

Refer to the section [Installation in a 19" cabinet and rack](#) in the *Product presentation and installation guide* for more information.

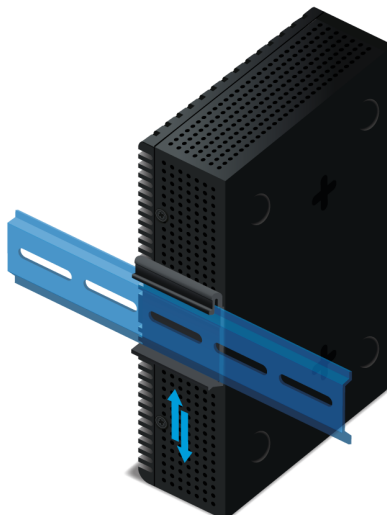



Installing firewalls against a wall

Refer to the section [Installation in a 19" cabinet and rack](#) in the *Product presentation and installation guide* for more information.

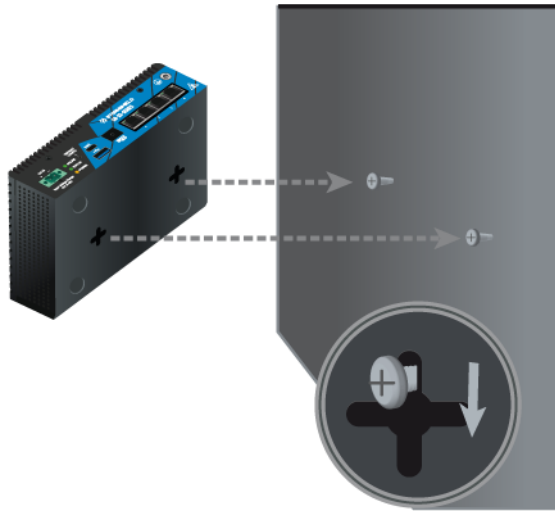



Plugging in and starting the firewall

Plugging in the firewall

1. Connect the firewall to its power supply. Refer to the section [Installation precautions](#) in the *Product presentation and installation guide* for instructions.

! IMPORTANT

For installations in a cabinet, equipment has to be reliably earthed. Particular attention should be given to supply connections other than direct connections to the branch circuit (e.g. use of terminal blocks)

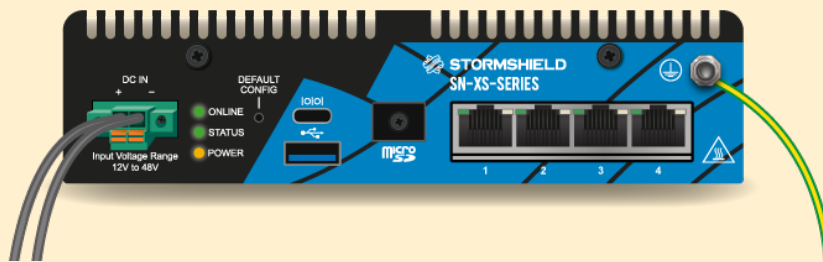

Once your firewall has been powered up, it will automatically start up. Wait for several minutes until the *Status LED* lights up.

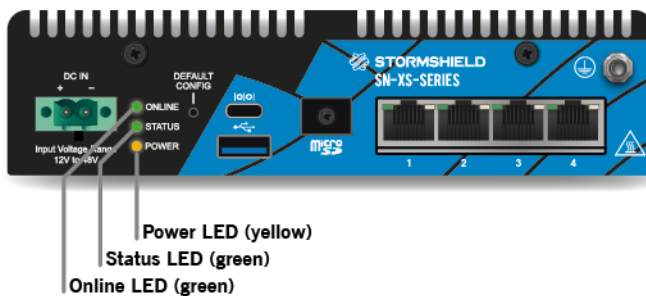

2. Connect the network ports as follows:
 - External interface on port 1 (OUT),
 - Internal interface (administration interface) on port 2 (IN).

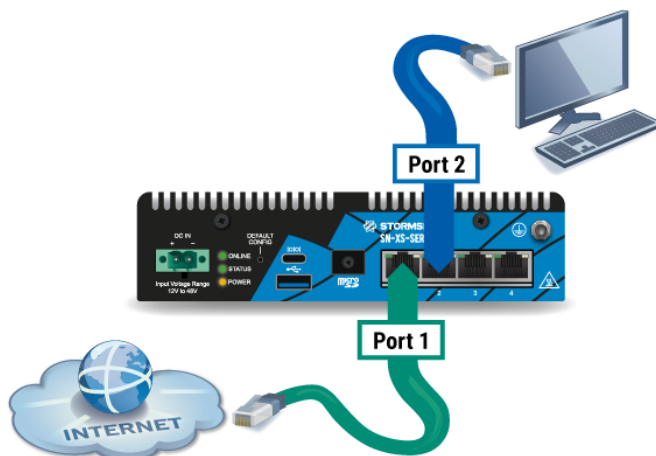



Connecting to the firewall

1. Using your client workstation, log in to the administration interface at the following address: <https://10.0.0.254/admin>.
2. Enter **admin** as the login and password.
3. During the initial connection, a warning message may appear in your browser. Confirm that you wish to continue accessing the administration interface.

When you encounter hardware issues on your firewall, or if any of the components does not match its description, contact your certified partner.

Troubleshooting

I am unable to connect to my firewall

Check the configuration on your client workstation. DHCP has to be enabled on this client workstation, or its IP address has to belong to the same address range as the firewall's [10.0.0.0/8].

I am unable to access the administration interface

If you have connected your client workstation over port 1, you will no longer be able to access the administration interface to resolve this issue:

1. Connect your client workstation on port 2.
2. Log in to the firewall in console mode (refer to the [Product presentation and installation guide](#)).
3. Restart the firewall.



Shutting down the firewall

To shut down your firewall:

1. Log in to the administration interface,
2. Go to **Configuration > System > Maintenance > Configuration**.
3. Click on **Shut down the firewall**.
4. Wait for several minutes until the *Power* LED turns to yellow.



Documentation

Log in to the following address to access your MyStormshield personal area, or to create one:
<https://www.mystormshield.eu>.

Your personal area allows you to:

- Register your product,
- Activate and manage your user licenses and software options,
- Download the latest updates,
- Subscribe to technical and marketing mailing lists.

You can access the technical support department's Knowledge Base from your personal area or the following address: <https://kb.stormshield.eu>.

Documentation on Stormshield Network firewalls can be accessed online, offering various resources (user guides, technical notes, etc.) : <http://documentation.stormshield.eu>.

For more information, refer to the [Product presentation and installation guide](#).



STORMSHIELD

documentation@stormshield.eu

All images in this document are for representational purposes only, actual products may differ.

Copyright © Stormshield 2024. All rights reserved. All other company and product names contained in this document are trademarks or registered trademarks of their respective companies.